

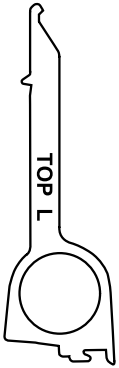

MOPAR®

CHRYSLER CROSSFIRE

Navigation Radio



A

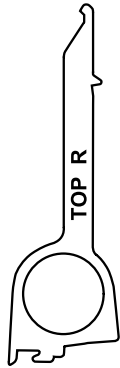

B

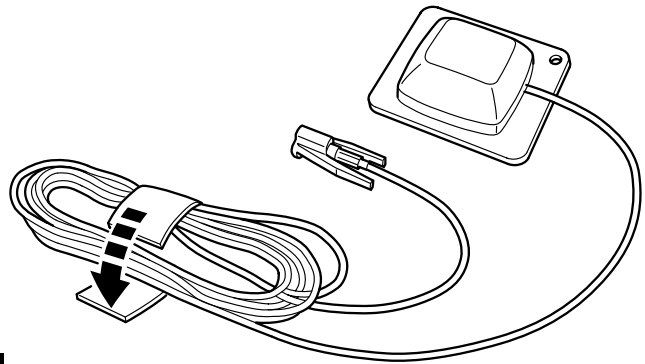

C

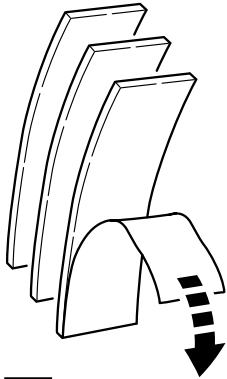

D 3x



E

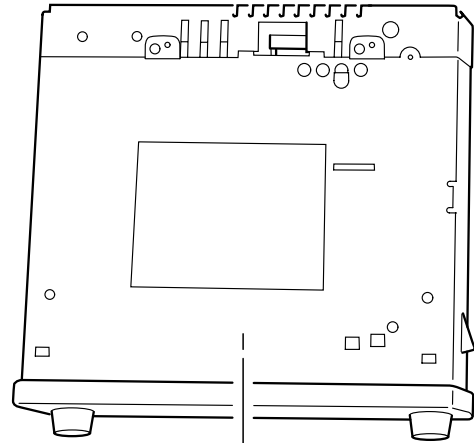

F

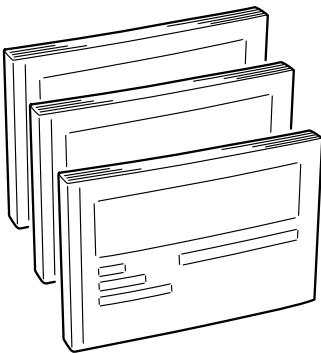

G 3x

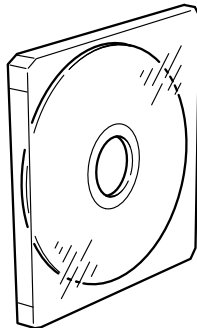

H

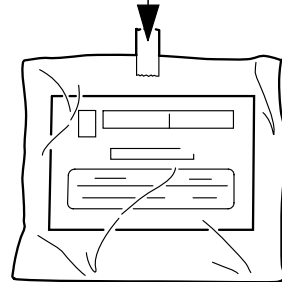

I

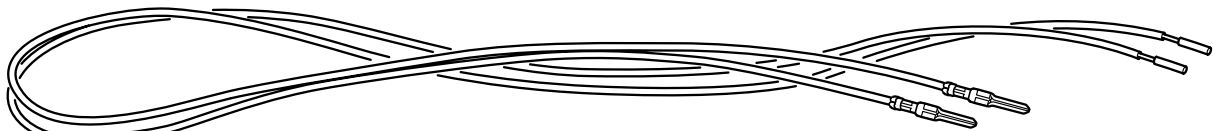

J

<p>GB</p> <ul style="list-style-type: none"> ■ Route wires away from sharp edges. ■ Follow the calibration procedures that are included in the Navigation Unit kit. ■ Some vehicles may be pre-wired at the radio connector and the jumper wires (Item J) will not be required. 	<p>D</p> <ul style="list-style-type: none"> ■ Stellen Sie sicher, daß die Drähte keine scharfen Kanten berühren. ■ Führen Sie den Kalibrierungsvorgänge aus, die im Kit des Navigationsgeräts enthalten sind.
<p>E</p> <ul style="list-style-type: none"> ■ Mantenga los cables protegidos de bordes afilados. ■ Seguir los procedimientos de calibración incluidos en el kit de la Unidad de navegación. 	<p>F</p> <ul style="list-style-type: none"> ■ Évitez de placer les fils électriques près de bords coupants. ■ Suivre la procédure d'étalonnage fournie dans le kit du module de navigation.
<p>I</p> <ul style="list-style-type: none"> ■ Non fare passare i cavi nelle vicinanze di spigoli vivi. ■ Attenersi alle procedure di taratura allegate al kit dell'unità di navigazione. 	<p>NL</p> <ul style="list-style-type: none"> ■ Leg de bedrading niet langs scherpe randen. ■ Volg de kalibratieprocedures. Deze vindt u in de kit van de Navigatie-eenheid.
<p>DK</p> <ul style="list-style-type: none"> ■ Før ledningerne uden om skarpe kanter. ■ Følg kalibreringsvejledningen, der fulgte med i navigeringsenhedskittet. 	<p>S</p> <ul style="list-style-type: none"> ■ Dra ledningarna så att de inte vidrör vassa kanter. ■ Följ kalibreringsprocedurerna som medföljer navigeringsenhetssetsen.

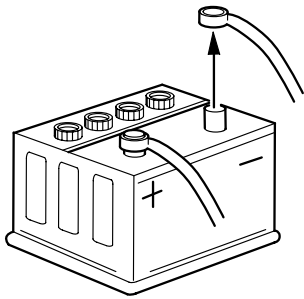

A

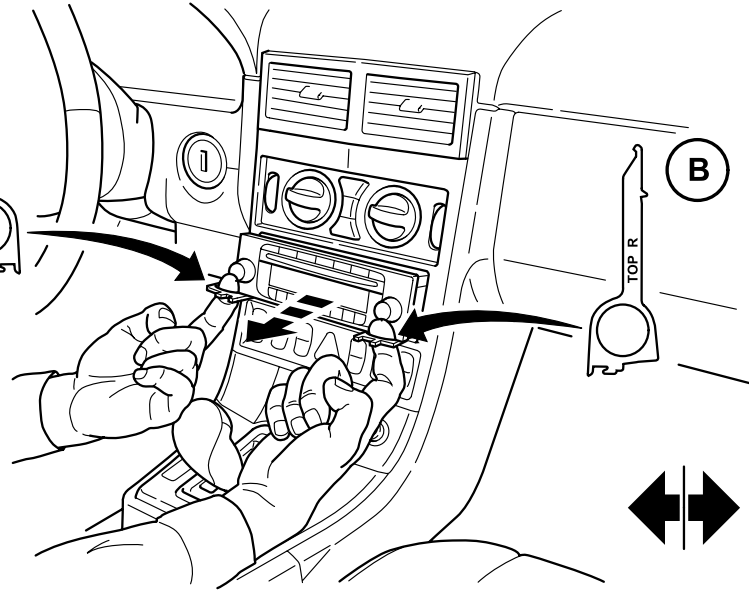
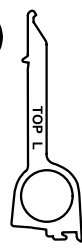

1

2

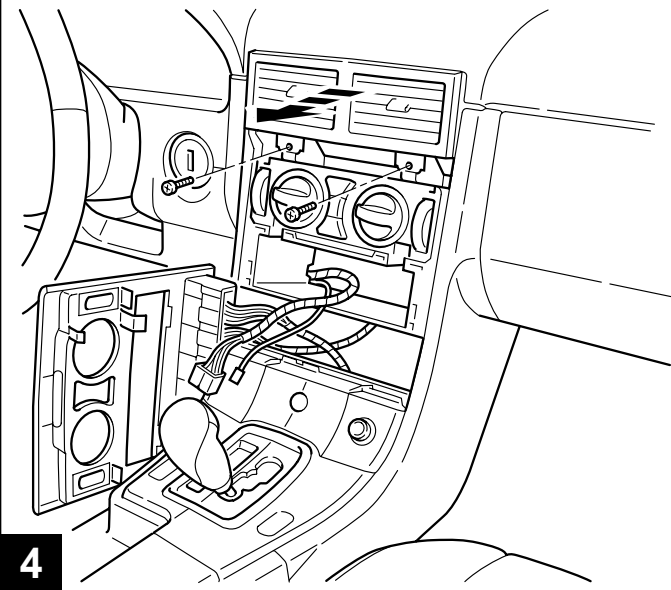
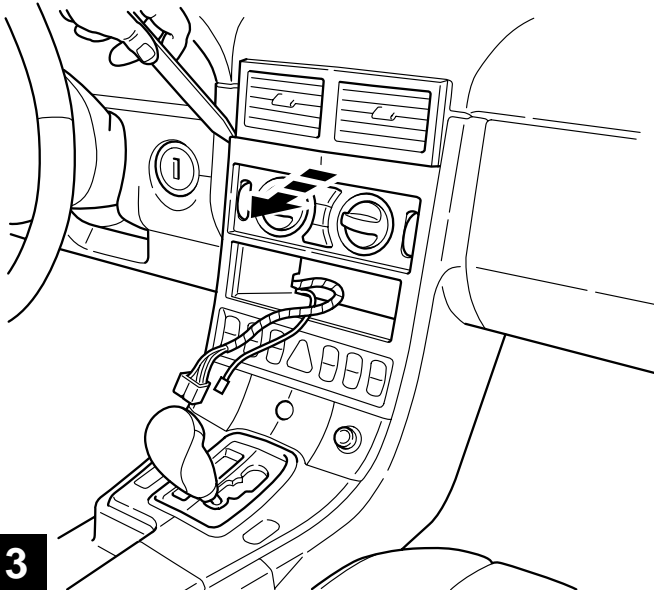

3

4

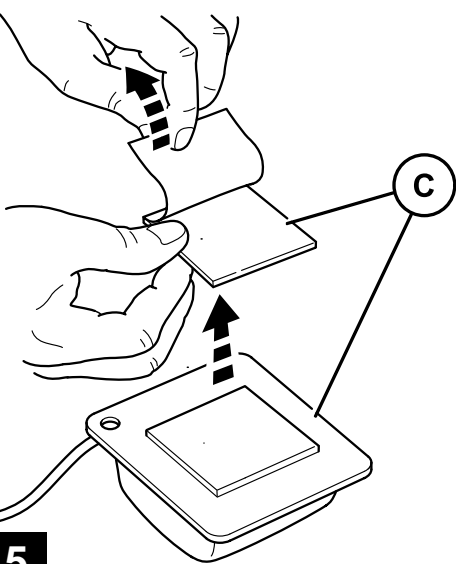

C

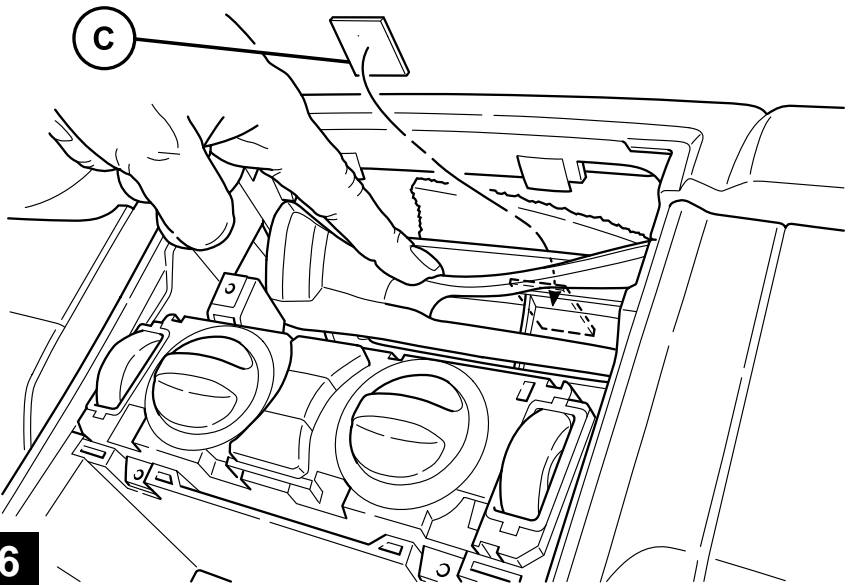

5

6

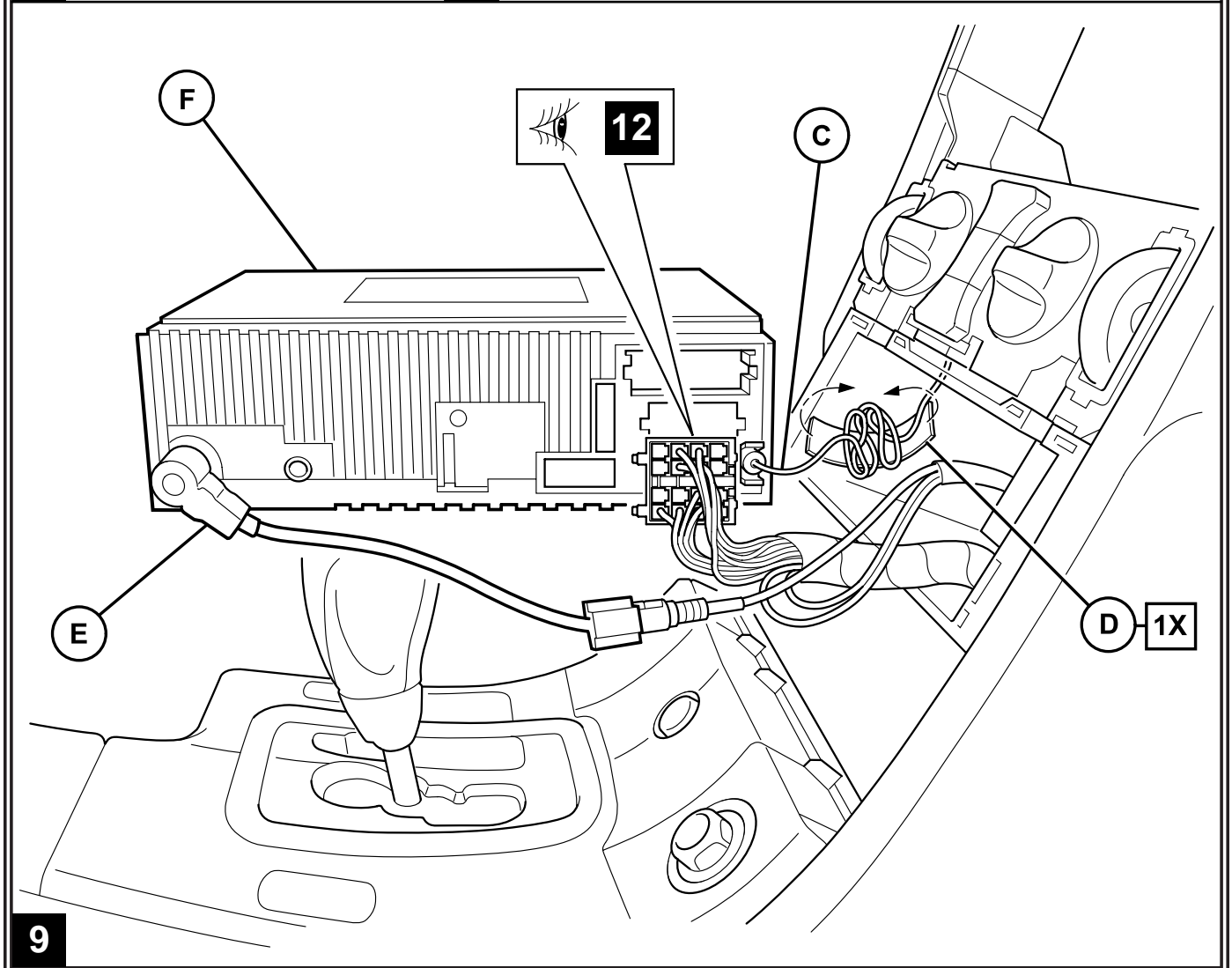
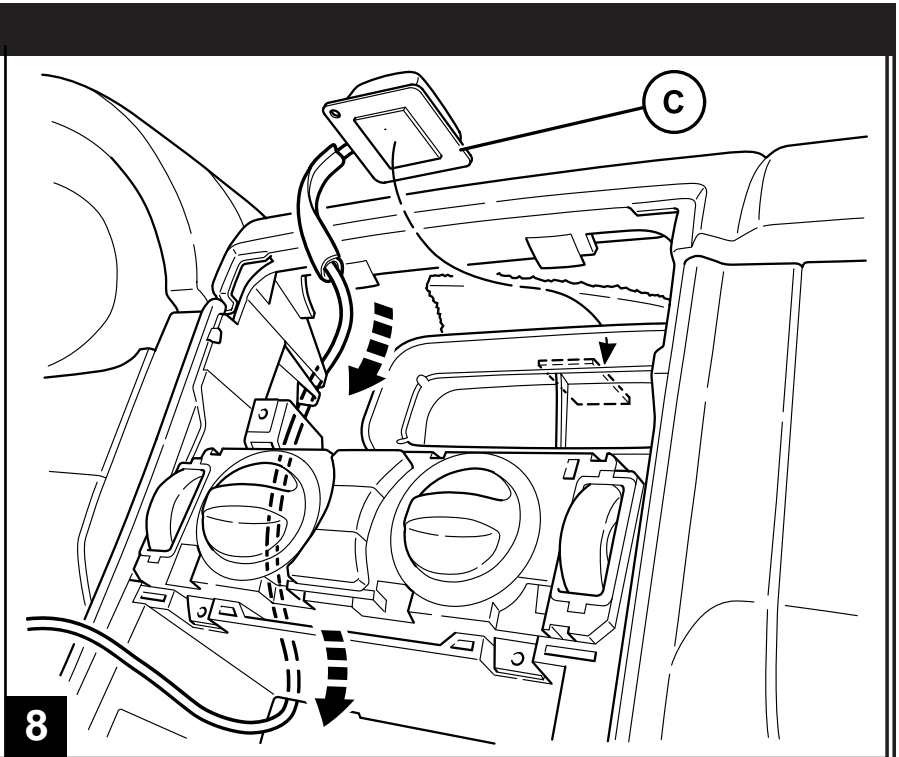
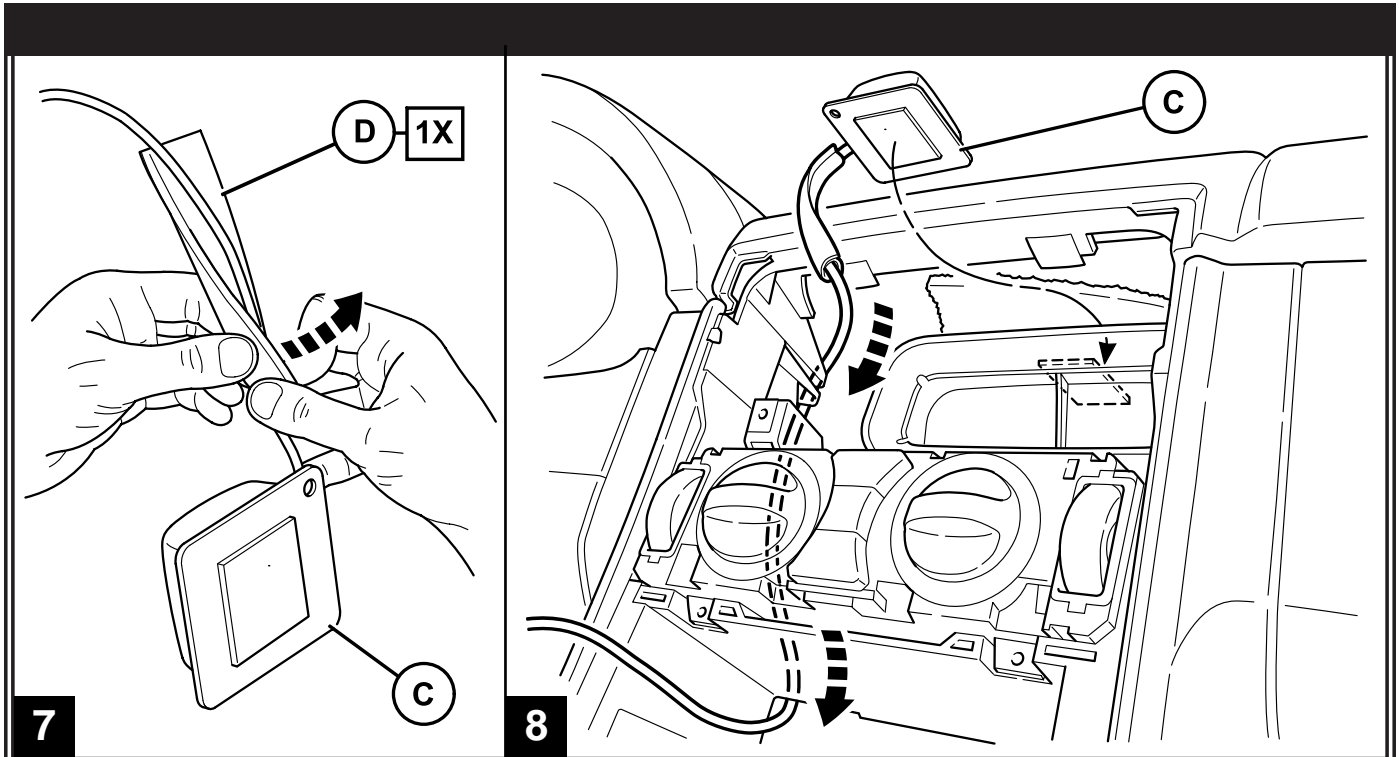

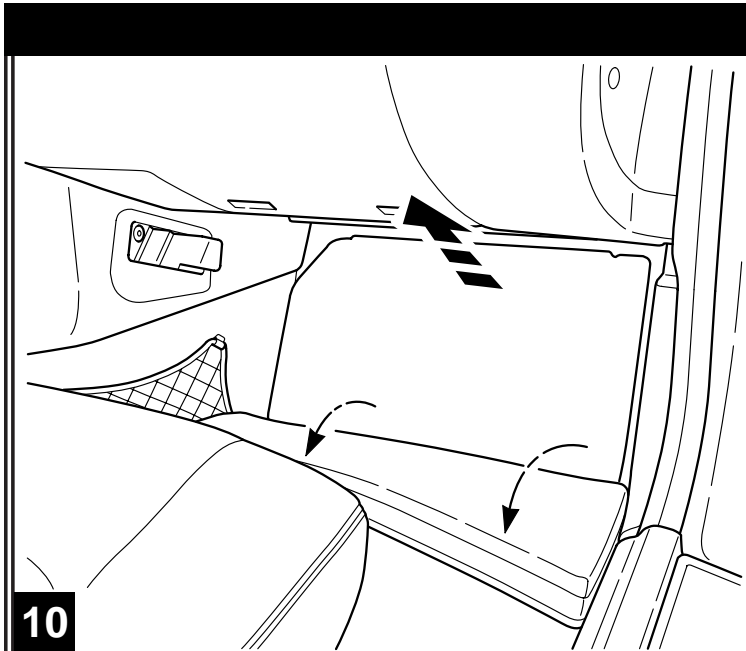

10

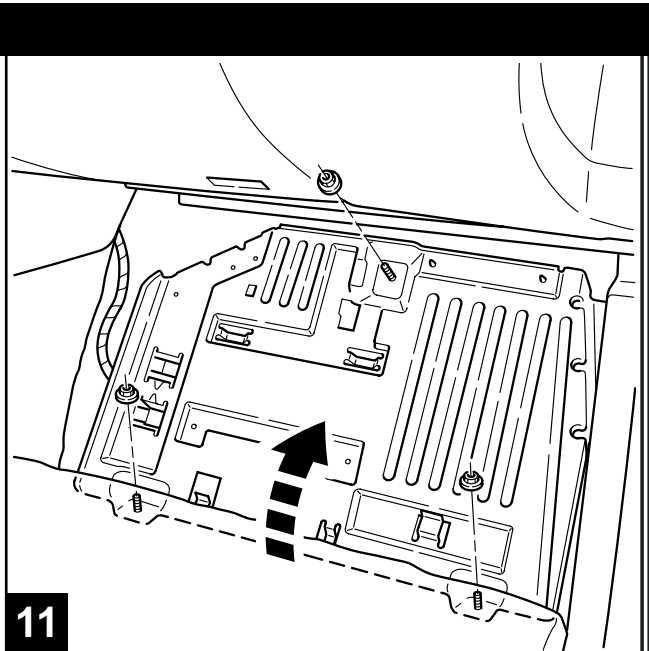

11

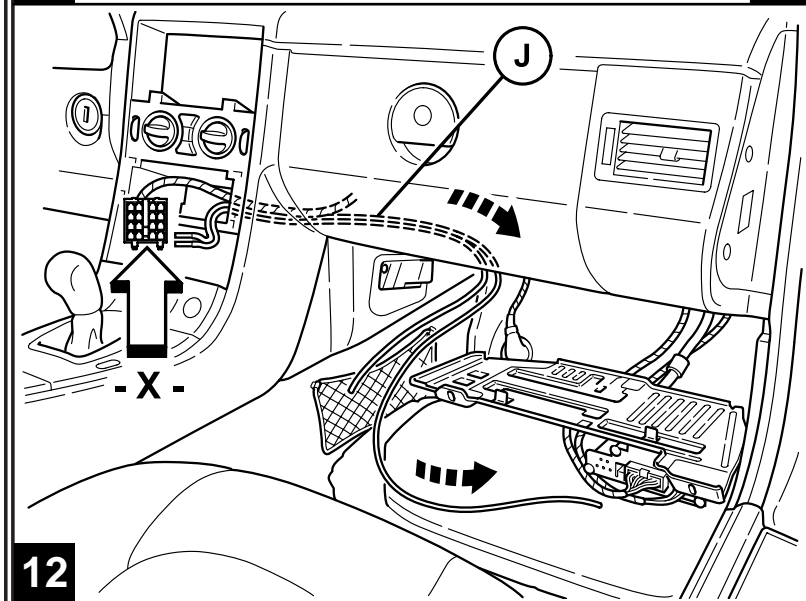

12

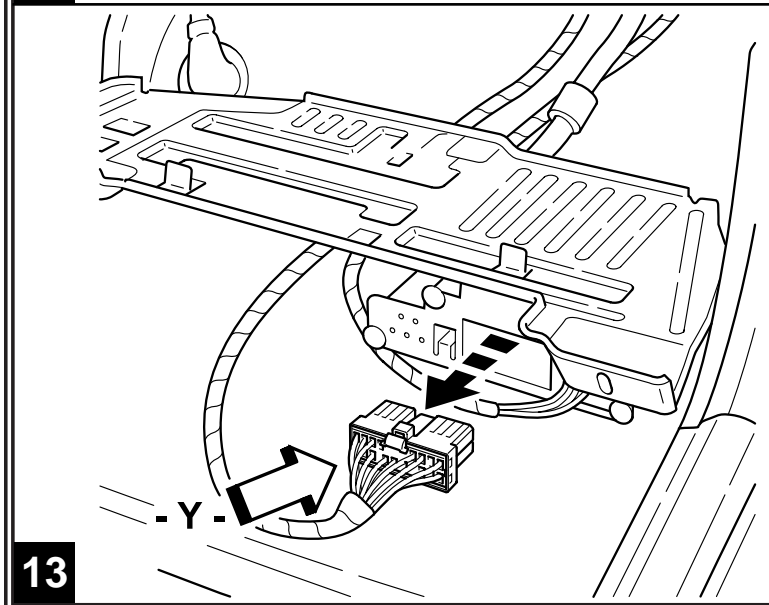
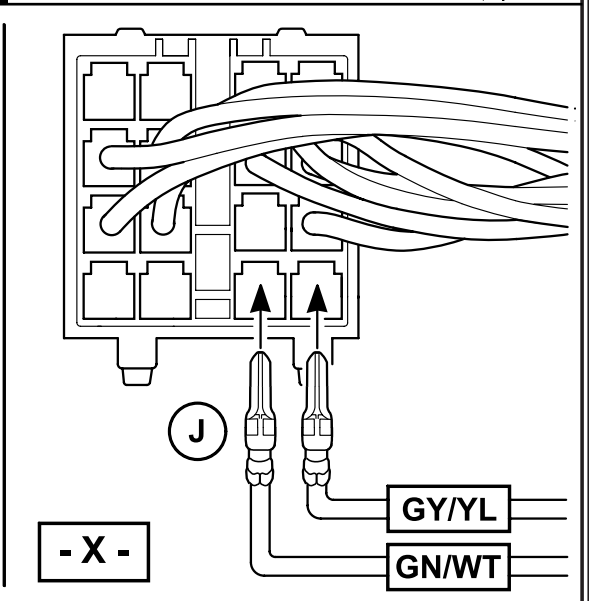

13

